

NOTE: Delayed Trigger can clash with other signals!
This may need checking (by the ROD?).

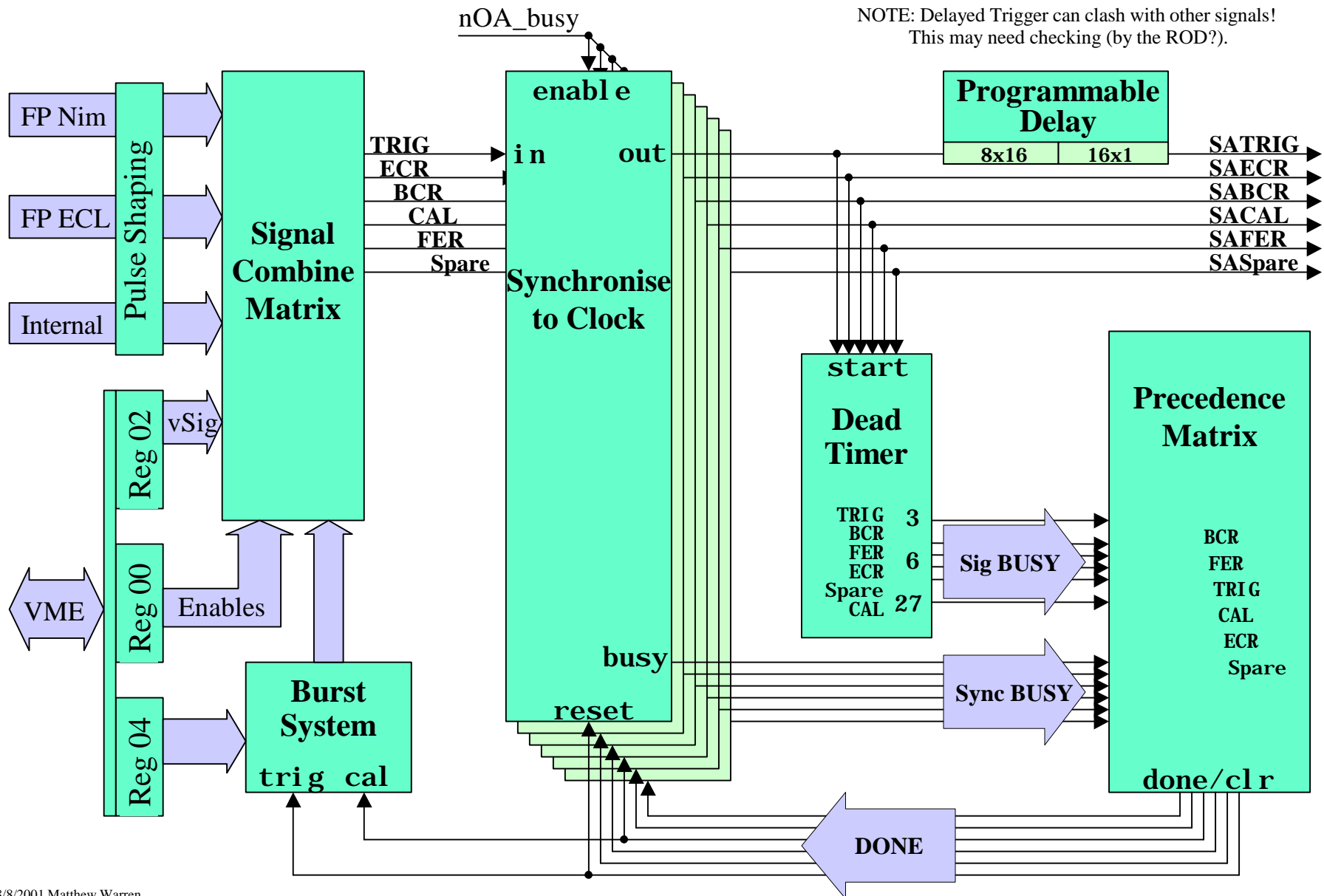

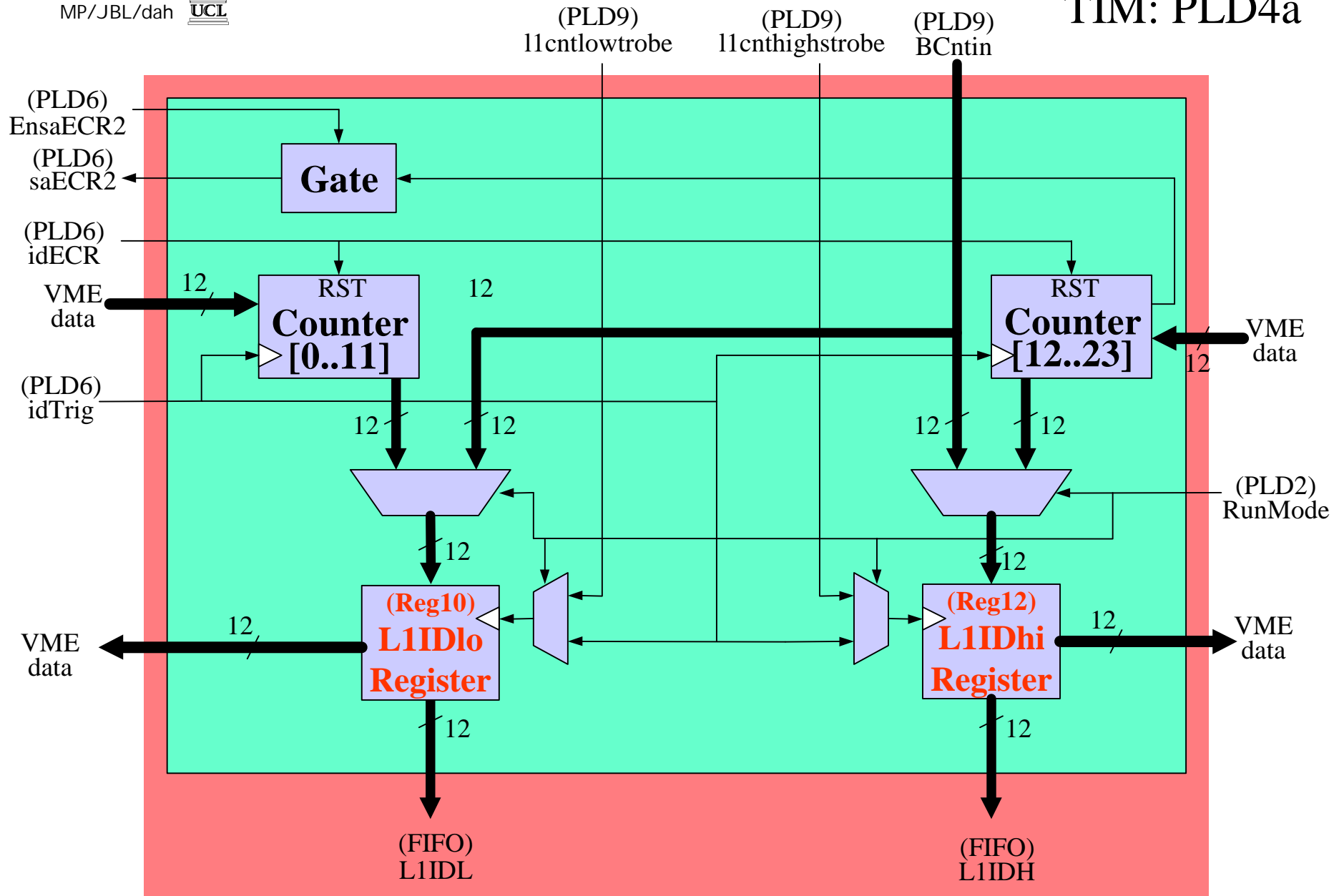

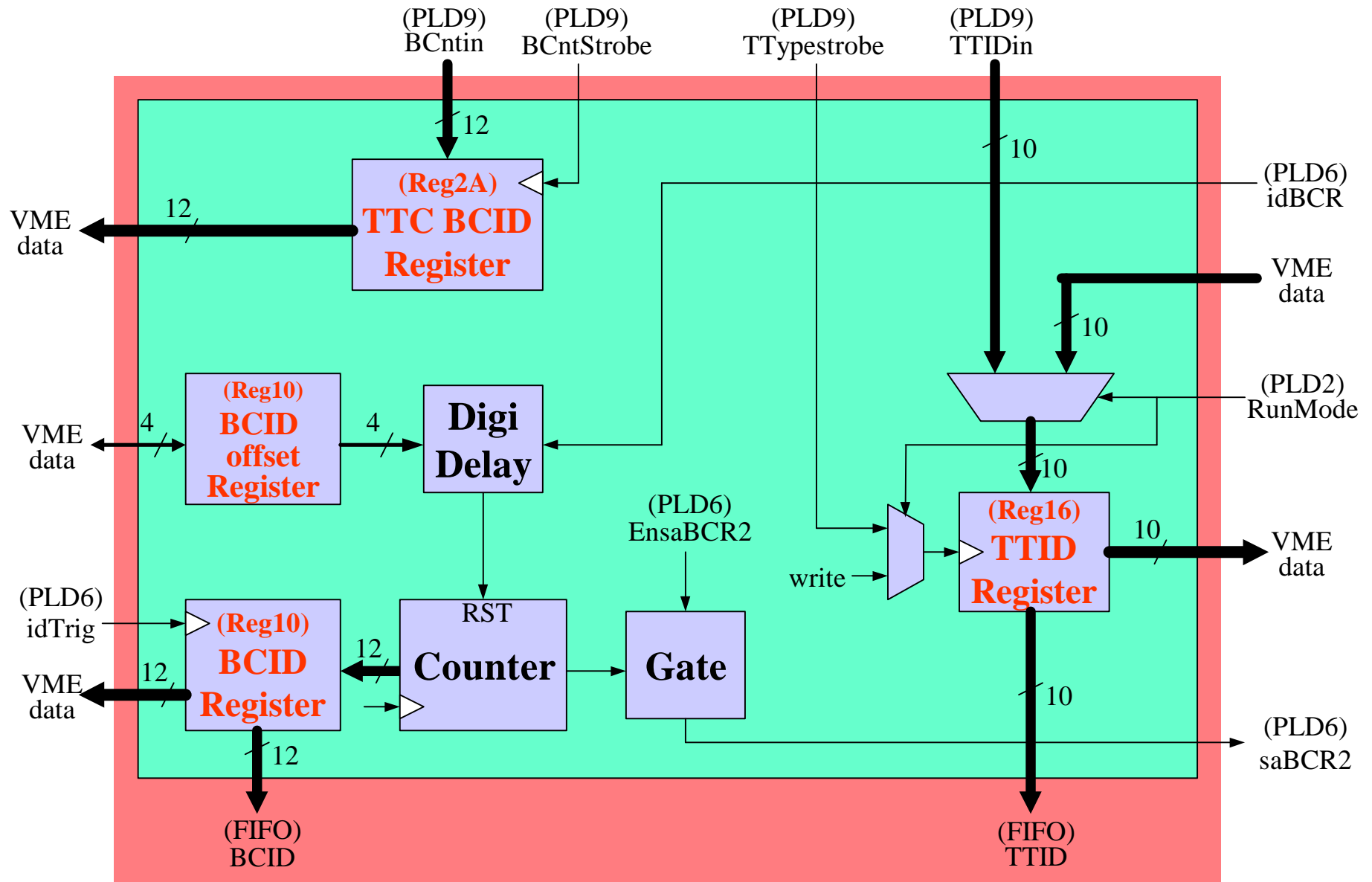



TIM: PLD5 & FRIENDS

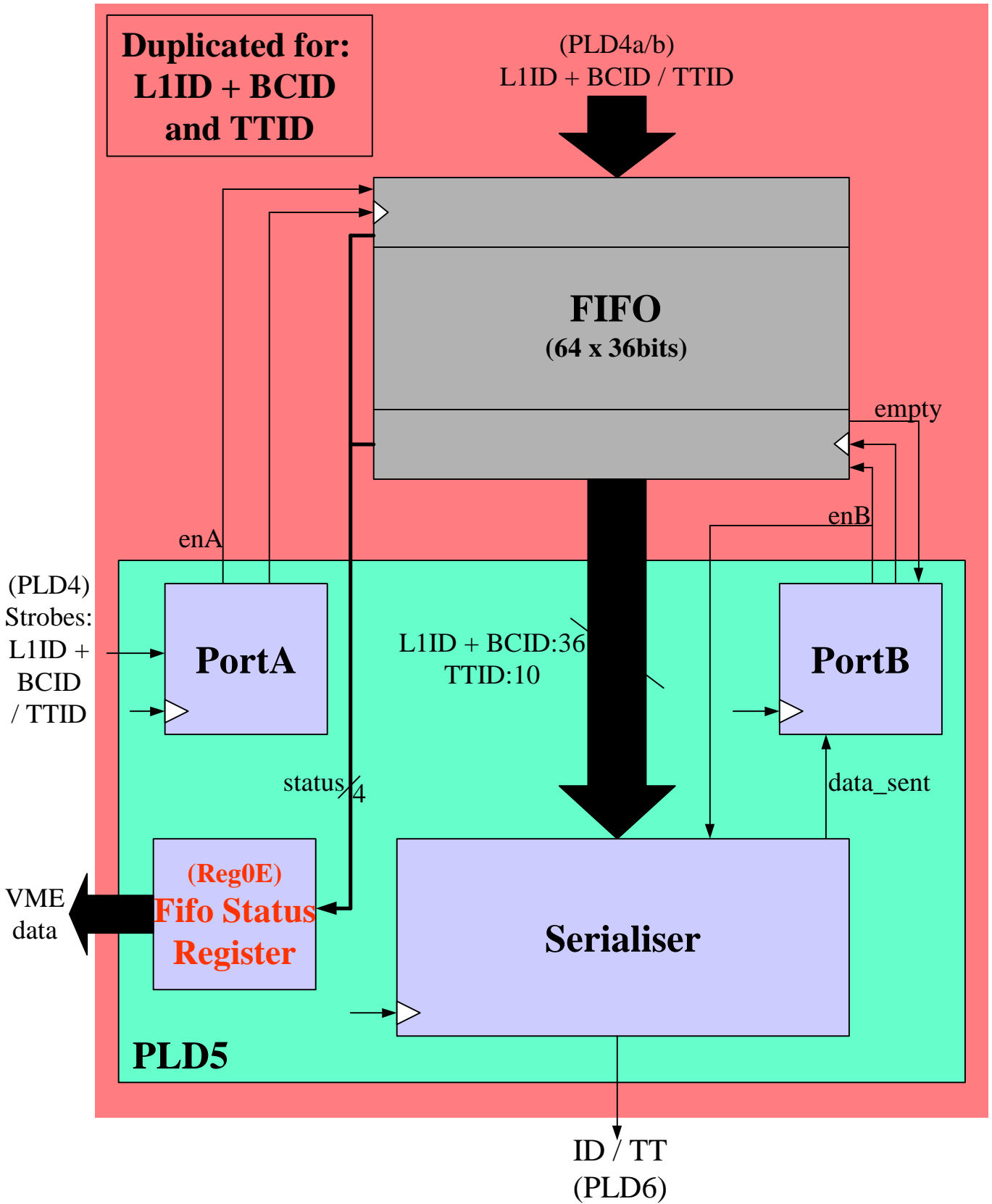

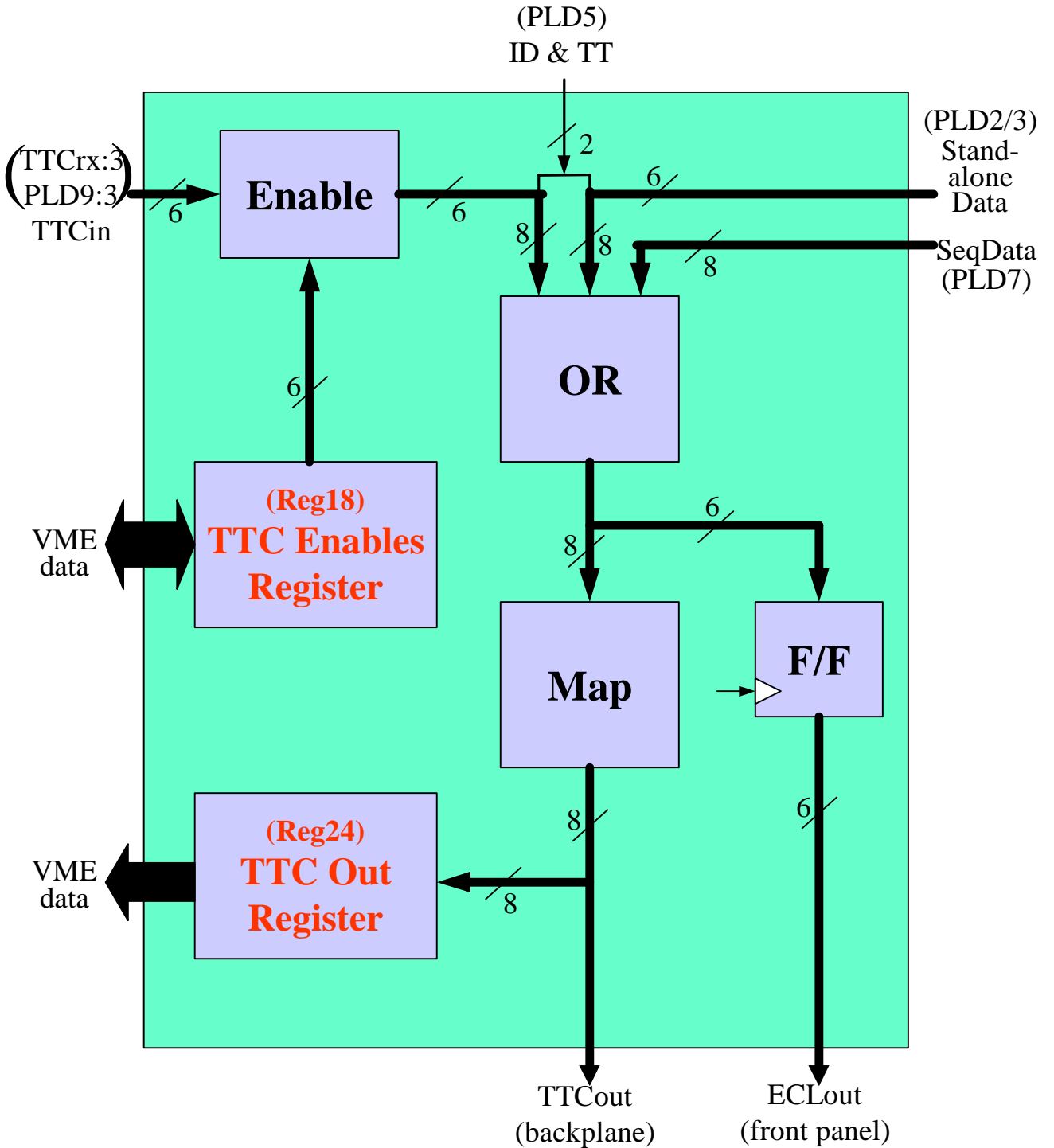

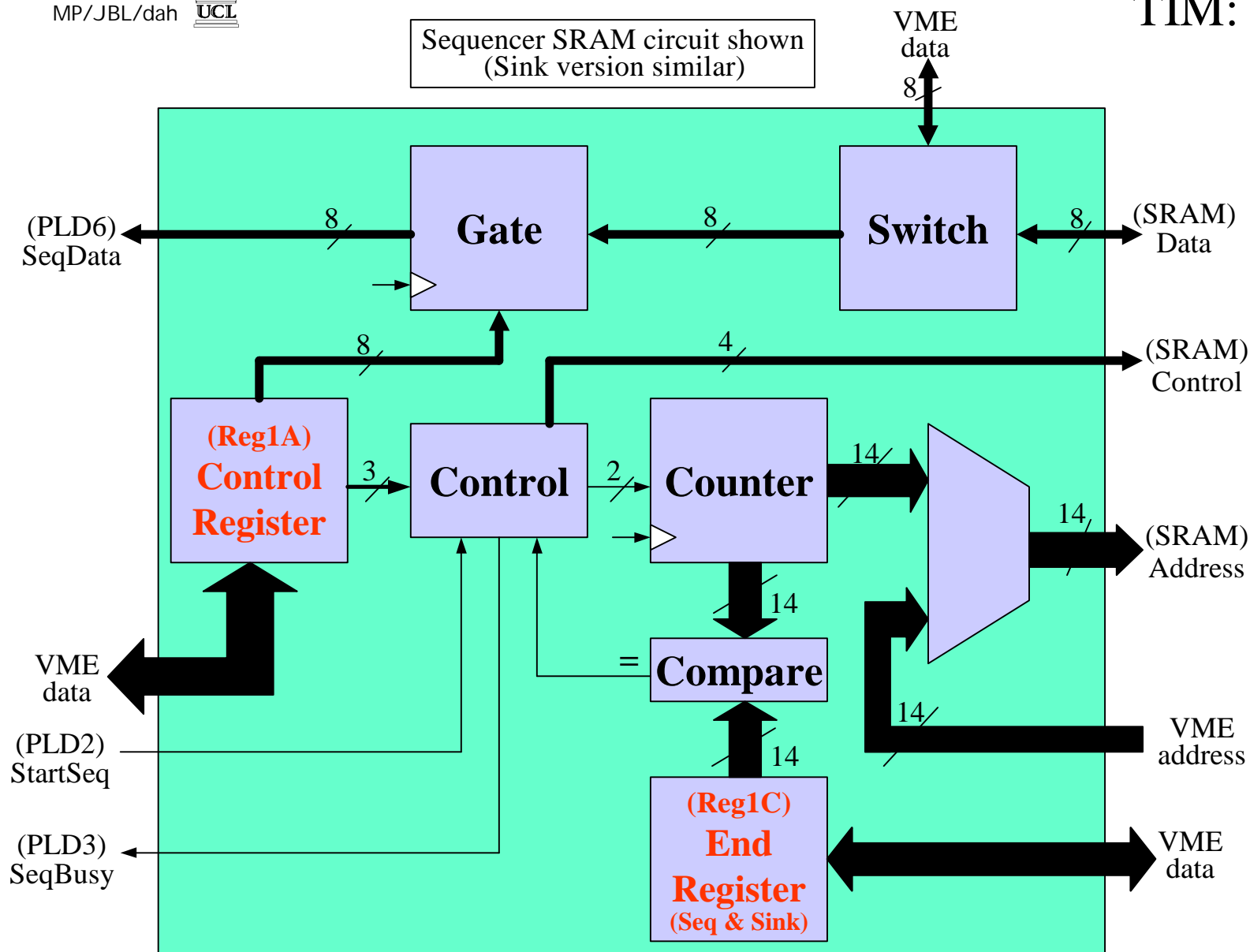

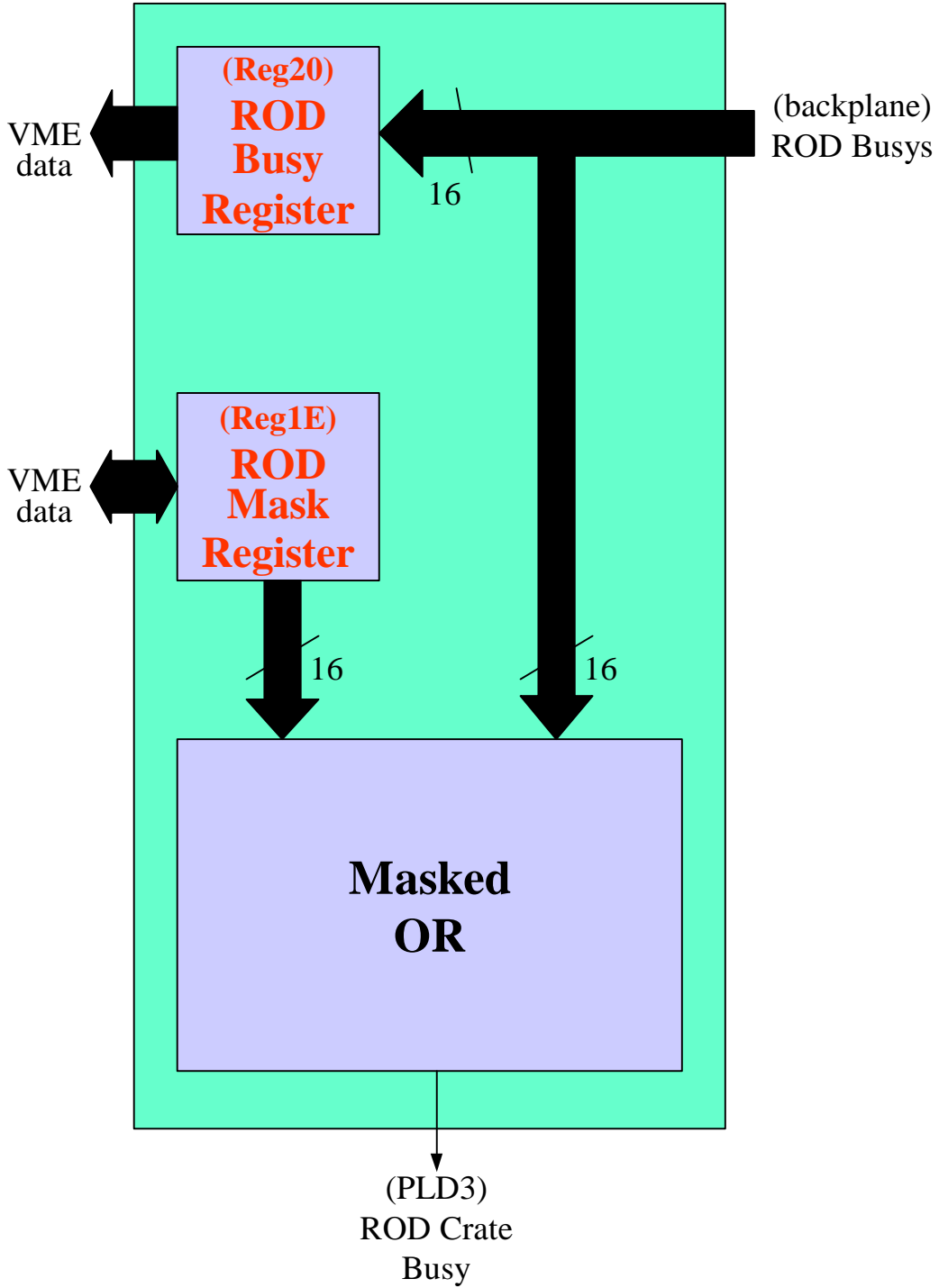

TIM: PLD9

