

Trigger and Data Acquisition Systems

Monika Wielers

RAL

• Lecture 3

• Trigger

Reminder from last time

- Last time we learned how to build a data acquisition system
- Studied several examples of data acquisition systems at the LHC
- We learned what a trigger is and how it works
 - Tells you when is the “right” moment to take your data
 - Decides very rapidly what output to keep if you can't keep all of it. The decision is based on some ‘simple’ criteria
 - Can be done in several levels
- Now we'll learn more how the trigger looks and how to devise the set of triggers needed for a physics analysis

Why do I need a trigger at the LHC?

- ❗ Huge incoming rate of mainly “uninteresting” collisions
 - ❗ Huge rejection needed from $\sim 10^9$ Hz to $\sim 10^2$ Hz for offline storage (physics analyses)
- ❗ Impossible to save all collisions
 - ❗ Would result in $O(100000)$ PetaByte or $O(1000)$ Exabyte per year of data per experiment
 - ❗ For comparison: 5 Exabytes: All words ever spoken by human beings.

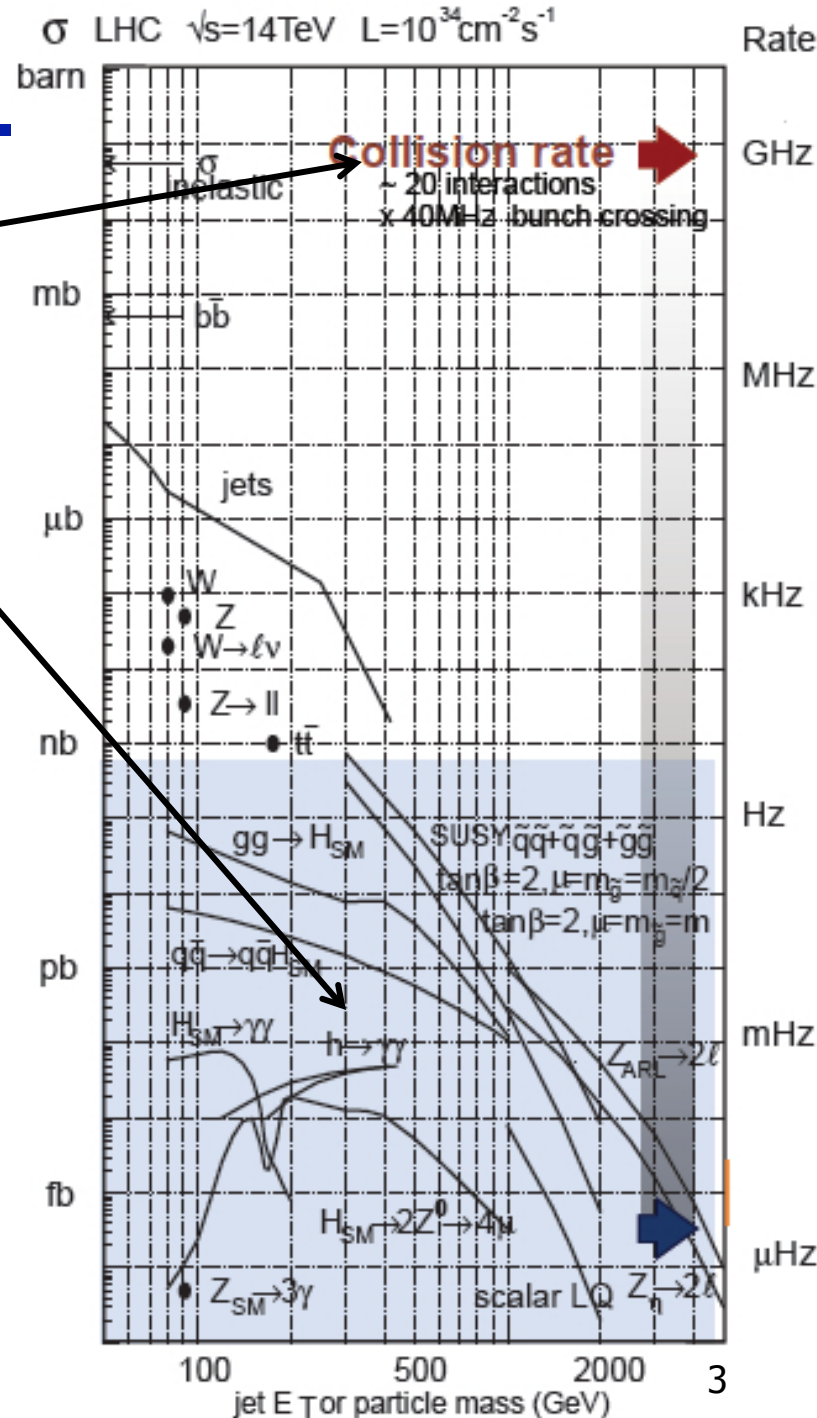

Trigger = Rejection

- Problem: We must analyse and reject most collisions prior to storage
- Solution: Trigger
 - Fast processing
 - High efficiency for interesting physics
 - Huge rejection factor $10^4 - 10^5$
- Note if the incoming rate is very high, the trigger itself is a 'severe' physics decision
- Make sure your favourite physics channel is selected with high efficiency
 - Many other trigger needed by other physics analyses will compete with you



Example: $H \rightarrow \gamma\gamma$

- Roughly one 125 GeV Higgs for every 10 billion pp interactions
- $H \rightarrow \gamma\gamma$ is rare decay with BR $\sim 10^{-3}$
- Approx. 1 $H \rightarrow \gamma\gamma$ per 10 trillion interactions
- Make sure you select them all....

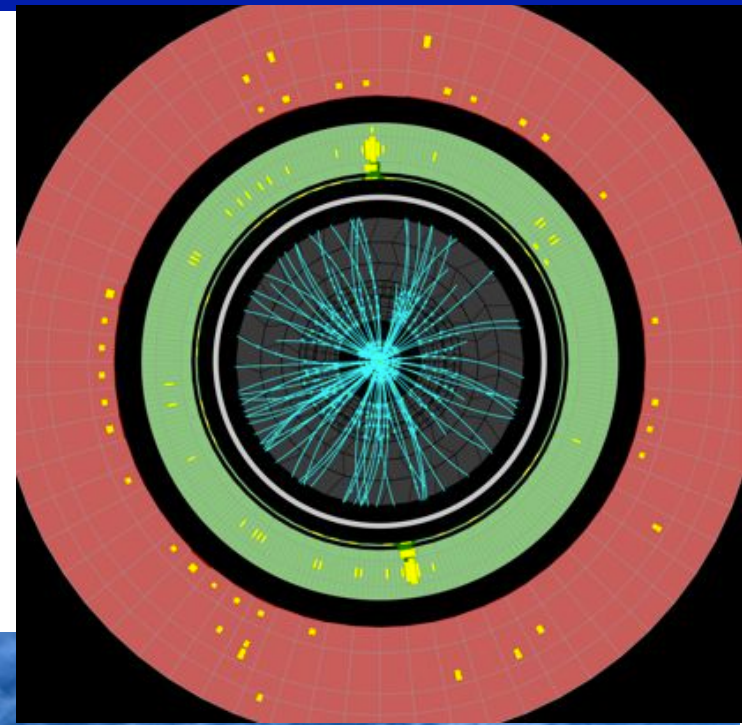

Other Challenges

- Pile-up (overlapping collisions)
 - Bunch crossing frequency of 40 (20) MHz in 2015 (2012)
 - LHC produced up to ~ 30 overlapping p-p interactions in 2012, expect 50-80 in 2015. Every bunch crossing \sim few 1000 particles are produced
- It's on-line (cannot go back and recover events)
 - need to monitor selection - need very good control over all conditions
- Any event thrown away is lost for ever!



“Simple” Trigger

- Example: dark matter experiment
 - Detect a very small energy deposition seen as a scintillation light from i.e LXe or LAr.
 - As there is only a low background can afford to select all events
 - Trigger rate: $\sim 100\text{Hz}$

Multi-level trigger system

- Sometime impossible to take a proper decision in a single place
 - Too many readout units
 - Too far away (transport signal)
 - Too long decision time
- Distribute the decision burden in a hierarchical structure
 - Usually $\tau_{N+1} \gg \tau_N, f_{N+1} \ll f_N$
- Done in LHC experiments (see last lecture)

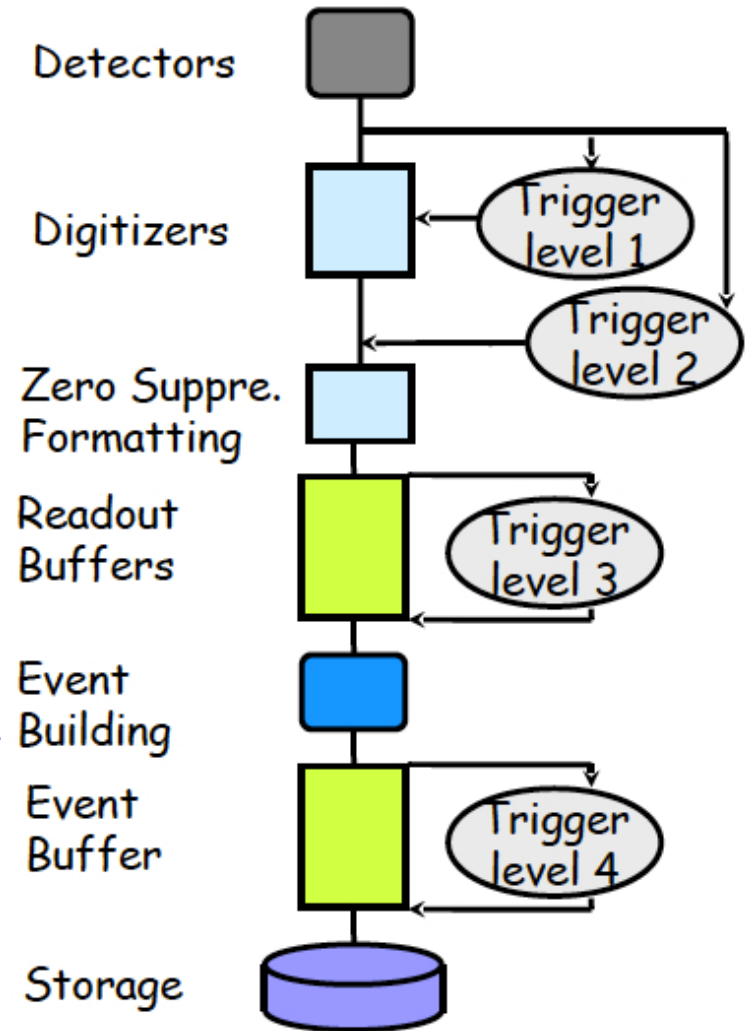

Example: Higgs

• L1

Coarse
granularity

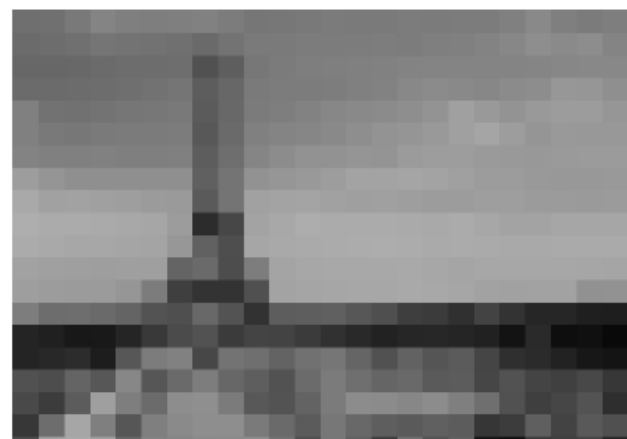
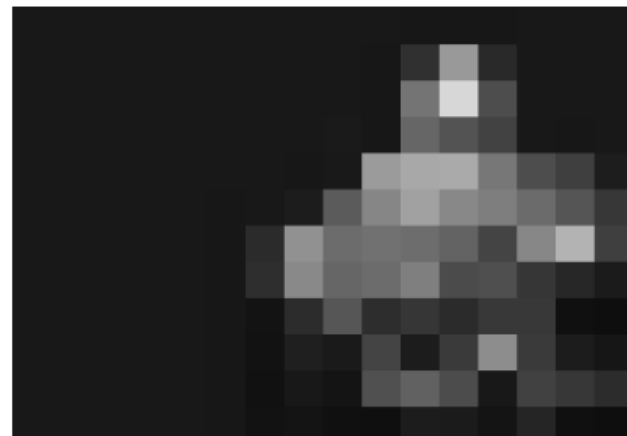

Example: Higgs

L2

Improved reconstruction,
improved ability to reject events

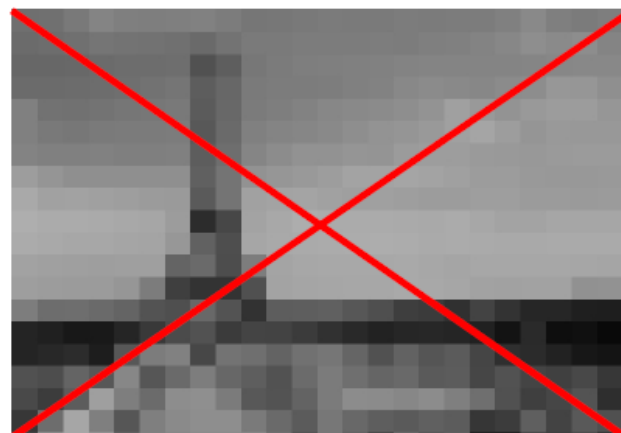
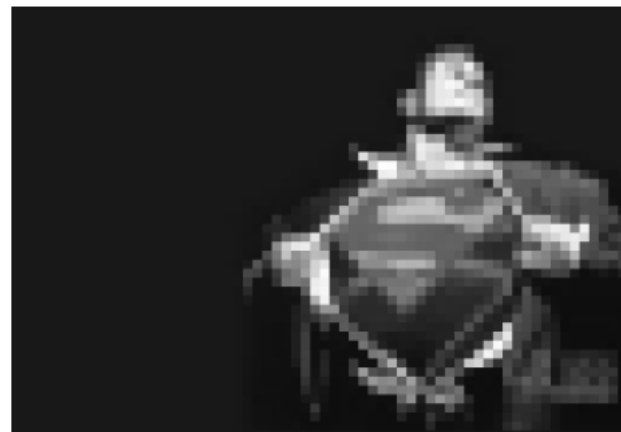

Example: Higgs

L3

high quality
reconstruction,
improved
ability to reject
events

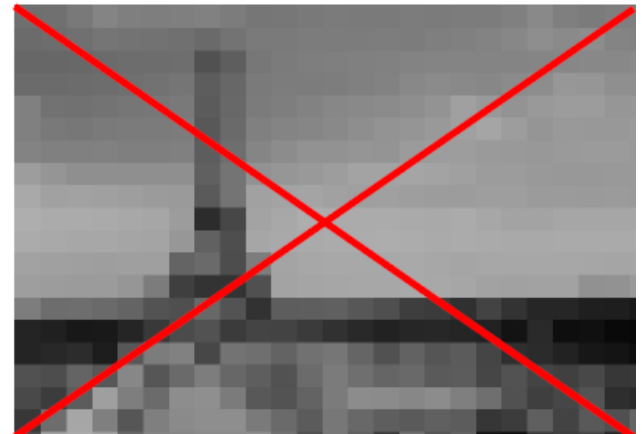
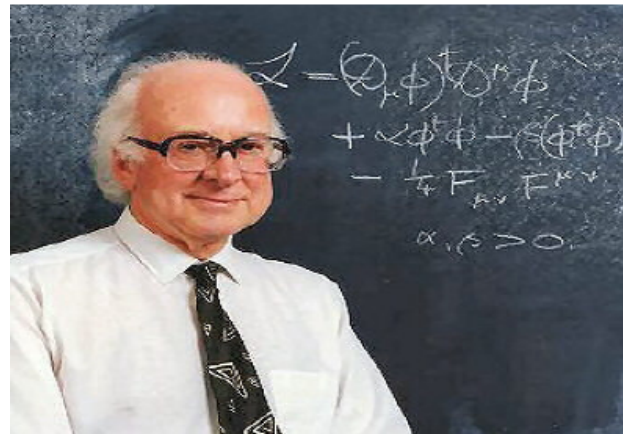
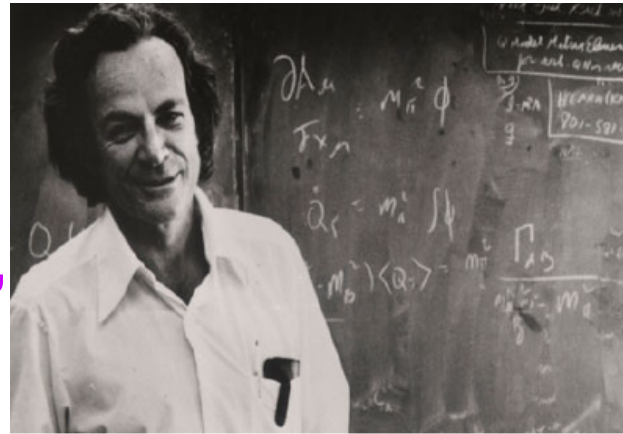

How do I select interesting collisions

Need to identify the different particles produced

Muons, electrons, photons, taus, jets missing E_T

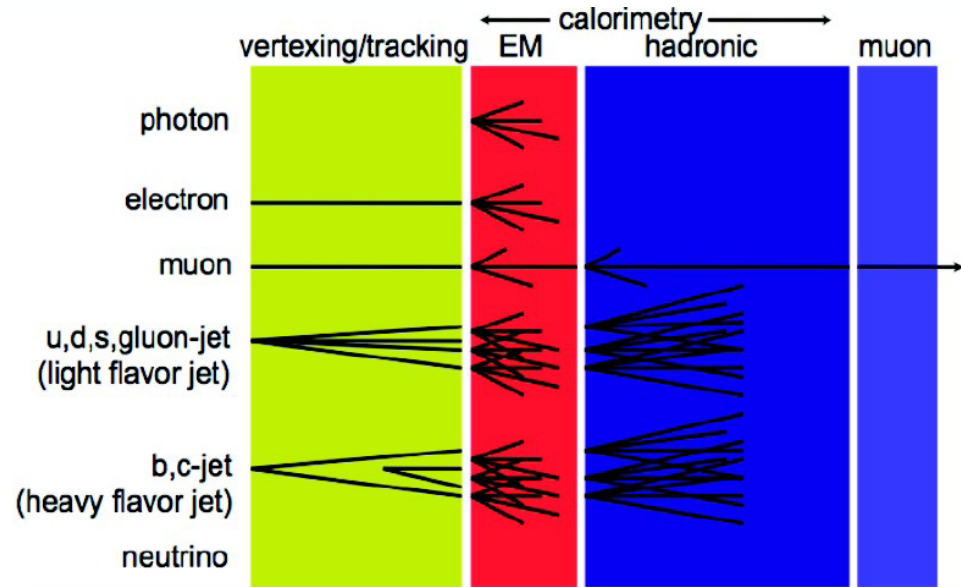

Detector feature (deposit in EM calorimeter)

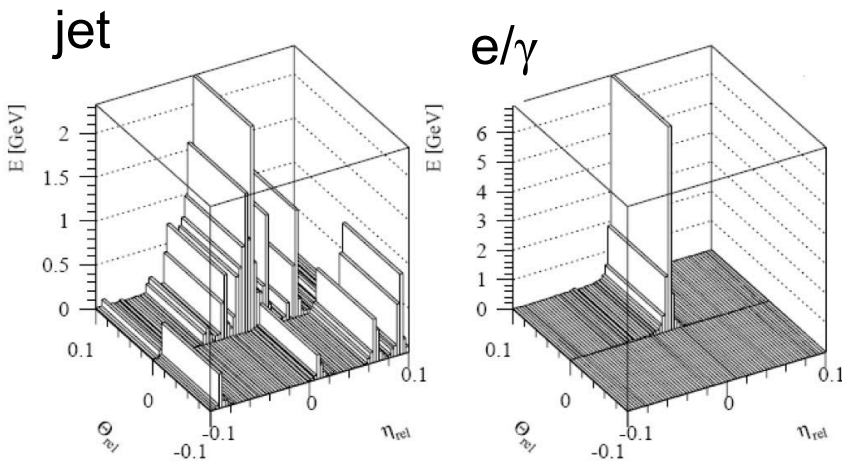

Trigger quantity

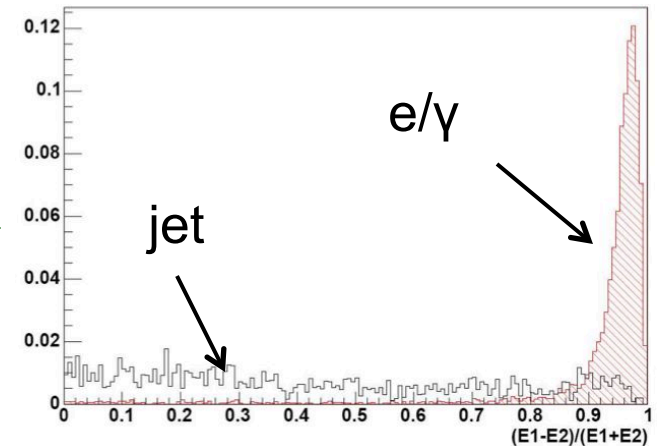

How do I select interesting collisions

- For each trigger / signature there is a chain of processing steps for each trigger level (L1, L2, L3,...)
 - Called: Trigger Chain, Trigger Path
 - E.g: reconstruct cluster - identify electron - reconstruct track - identify e^\pm

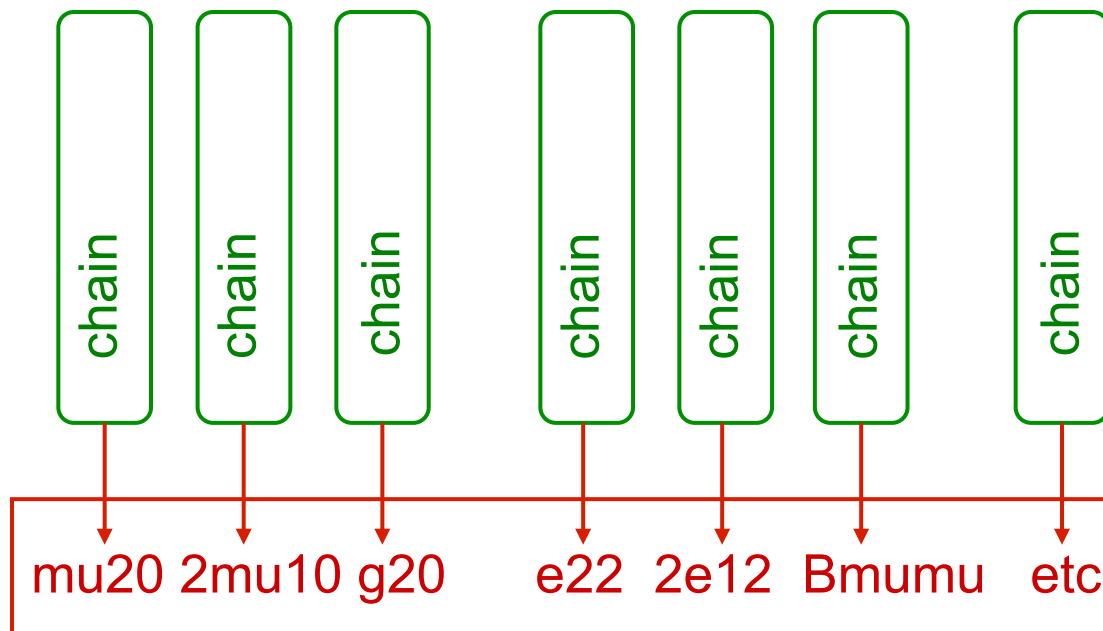

Trigger Path

- Use the identified particles above given (transverse) energy thresholds
 - Isolated electron, muon and photons
 - τ -, central- and forward-jets, jets from b-decays
 - Events with missing E_T , missing E_T significance
- You can select events according to multiplicity
 - E.g. one electron and one muon, 4 jets etc
- Or even more complicated (topological trigger)
 - Select events with a jet and a photon which are back-to-back
 - Select events with 2 γ 's with invariant mass \sim Higgs mass
- Each trigger item can be **prescaled**, thus only a fraction of the selected events is recorded.
- The set of triggers or trigger items to be run online is called **Trigger Menu**

Trigger Menu

- Prepare a Trigger Menu
 - Defines the physics we want to do at our experiment
 - Each trigger item is defined by trigger chains
 - Event is stored if one or more trigger items are passed
- Need flexibility
 - Cope with changing luminosities
 - Be able to add triggers if needed (e.g. new triggers upon discovery of new particles)
- In LHC experiments we ran 500-700 triggers online in 2012!



Today's Specials



Electrons

e24 (24 electron raviolis)	£7.95
2e12 (2 12 oz electron steaks)	£9.95

Muons

Mu24 (24 dl muon soup)	£5.95
2mu10 (2 pizze 10cm ☹)	£7.95

Jets

4j50 (4 jet pancakes)	£8:95
J500 (500g grilled jet fish)	£16:95

Mixed triggers

J50_ETmiss50 (yummy jet with missing french fries)	£10:95
Tau40_e20 (tau salad with electrons)	£8:95

What makes up a Menu

- **Physics triggers** (typically take all of them)
 - e.g. mu24 (one muon with $p_T > 24 \text{ GeV}$, useful for many analysis from SM to searches for new particles (Higgs, Susy, ...))
 - Obviously most of the trigger bandwidth is used for these
- **Supporting trigger or cross trigger** (typically prescaled)
 - Needed to understand (support) your physics analysis for e.g.
 - Measure trigger/offline efficiency
 - Understand your backgrounds
 - **Calibration Triggers**
 - E.g. select events selected by L1 only
 - **Monitoring triggers**
 - E.g. select $Z \rightarrow ll$ events
- **Trigger menu determines the physics we can do in the offline analysis!**

Trigger Menu

- Example from CMS: how menu changed as a function of luminosity

$L = 8 \times 10^{29} \text{ Hz/cm}^2$
Rate $\sim 200\text{-}300 \text{ Hz}$ (*)

Jets, MET, Tau: 15%
Electrons: 25%
Muons: 25%
“Support” Triggers: 50%

Early-Mid 2010

$L = 2 \times 10^{32} \text{ Hz/cm}^2$
Rate $\sim 300\text{-}500 \text{ Hz}$

Jets, MET: 30%
b, Tau: 15%
Electrons: 25%
Muons: 30%
“Support” Triggers: 10%

End 2010

$L = 2 \times 10^{33} \text{ Hz/cm}^2$
Rate $\sim 200\text{-}300 \text{ Hz}$

Jets, etc.: 20%
Tau: 5%
Electrons: 20%
Muons: 20%
Cross Triggers: 20%
“Support” Triggers: 5%

2011

(*) Numbers and fractions approximate,
and do not account for trigger overlap

How to design a trigger

- First understand the physics you want to do
 - Which are the particles in your final state and how high is their p_T ?
- Understand the existing trigger menu
 - Figure out if there is already a trigger in place which does the job
 - No need to design a new one if it's already covered
- If not, think up a new trigger
 - Can you combine several particles into one trigger, e.g. muon + 2 b-jets?
 - Can you take advantage of the topology of your event, e.g. invariant mass, back-to-back topology?
 - Also keep in mind that the trigger reconstruction is not as good as the offline one and your selections need to be looser
- Figure out if also other analyses might profit from your trigger
 - The more analyses there are the more likely your trigger will be accepted to run online

How to design a trigger

• General rule:

• Make it as simple as possible

- Less trigger losses

- Avoids unnecessary trigger biases in your analysis

- Less demand for supporting triggers

• If possible, create a new trigger based on a already existing (older more inclusive) trigger

- Already validated and easier to implement

Example: W cross section measurement (ATLAS/CMS)

- How do I reconstruct $W \rightarrow lv$, $l=e,\mu$ in the offline?
 - Select events containing 1 electron or muon with high transverse momentum ($p_T > 25$ GeV)
 - Select events with high missing transverse energy ($E_T^{\text{miss}} > 20$ GeV)
 - Calculate transverse mass

$$M_T^2 = (E_{T,1} + E_{T,2})^2 - (\vec{p}_{T,1} + \vec{p}_{T,2})^2$$

- Extract background and subtract
- Count events and convert in cross section

$$\sigma(\text{signal}) = \frac{(N_{\text{cand}} - N_{\text{bkg}})}{\alpha \cdot \epsilon_{\text{trig}} \cdot \epsilon_{\text{offline}} \cdot \int L dt}$$

- Trigger can select these events selecting high energetic electrons or muons and/or via E_T^{miss}
 - So what should I choose?

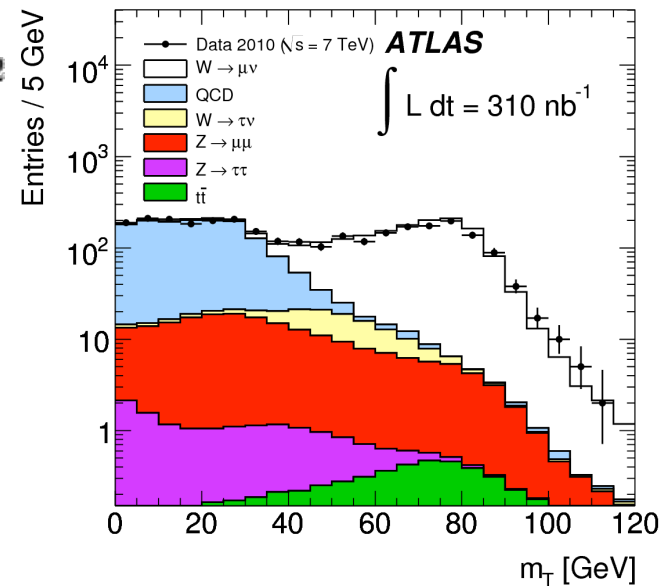

Example: Trigger for measuring W cross section

- E_T of the electrons and muons
 - Selection of $E_T > 20$ GeV e/μ 's will keep most of the W's
- ➔ Select events containing one high p_T e/μ
- Next: check the **turn-on** – trigger efficiency w.r.t. offline E_T near the trigger threshold
 - E.g. e^\pm -trigger with $E_T = 20$ GeV threshold (e20) efficient for offline $E_T > 22$ GeV, **plateau** for $E_T > 25$ GeV
 - ➔ Trigger threshold few GeV lower than what you want in offline analysis (resolution effect)
- Check the rate:
 - Assume: Rate ≈ 500 Hz
 - ➔ need higher threshold and tighter selection
 - ➔ Rate: 60 Hz

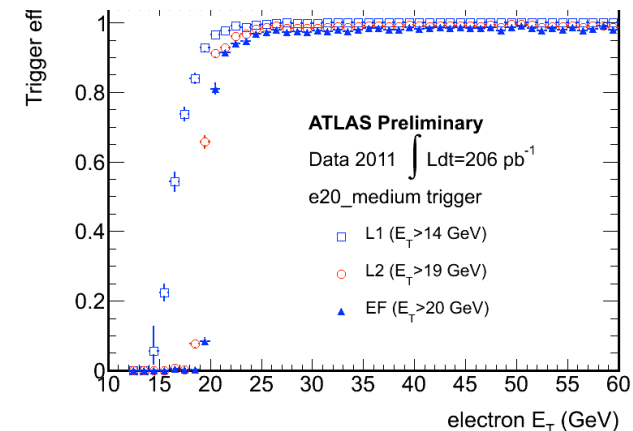
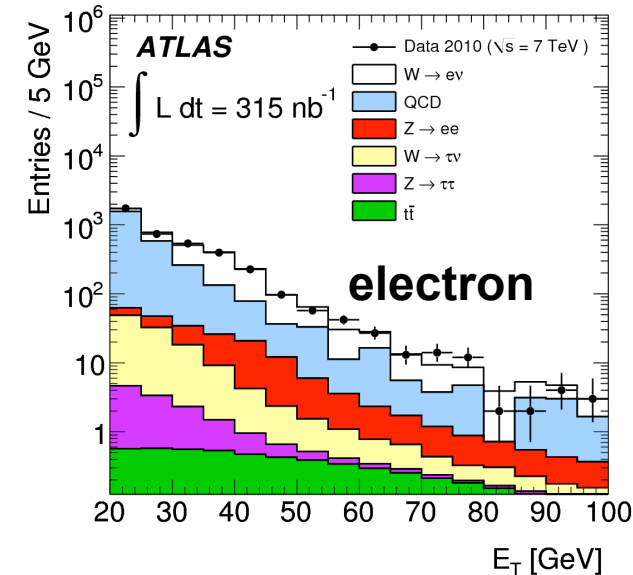

Example: Trigger for measuring W cross section

- And if the rate is still too high?
 - Even tighter selection (typical lower eff)
 - Even higher E_T
- Could we rather use missing E_T for the trigger?
 - Promising for $E_T^{\text{miss}} > 30$ GeV
- Let's look at turn-on for $E_T^{\text{miss}} > 30$ GeV
 - Efficient at offline $E_T^{\text{miss}} > 40$ GeV
 - Rate: ~ 5 kHz
- Combine E_T^{miss} with e/μ
 - e/μ with $E_T > 25$ GeV + $E_T^{\text{miss}} > 30$ GeV: 20 Hz
 - But now less analyses can use this trigger... perhaps rather higher E_T ?
 - Best compromise needed...

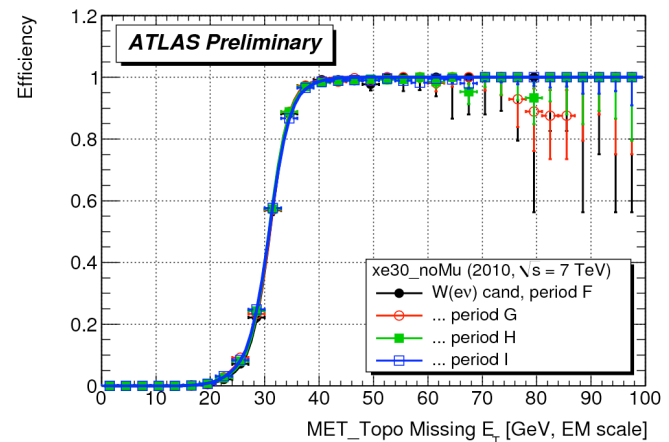
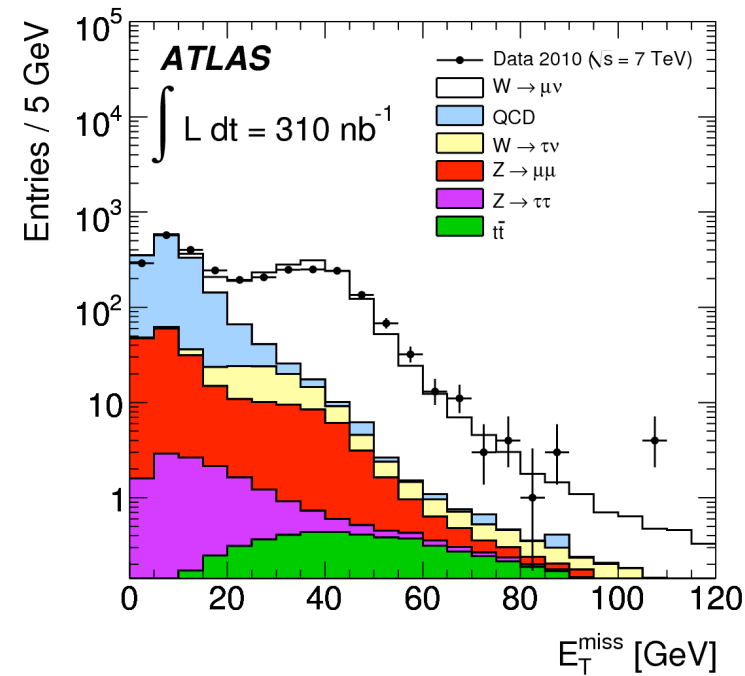

Example: Trigger for measuring W cross section

- Another possible solution if you do not need the full data statistics
 - Prescaling
 - Find out how many events you need to do a useful analysis!
- If you also want to measure $W+1, 2, 3$, etc jets cross section
 - Add another trigger selecting based on $e/\mu (+ E_T^{\text{miss}}) + \text{jets}$

What other triggers do I need: background trigger

• Now we e.g. select events with:

• $e/\mu + E_T^{\text{miss}}$

• I need to estimate the background under my signal

• Often done via cut-reversal (ABCD) method

• Need sample of events selected without or only loose electron selections

• e.g. need e_{25_loose}

• Do not need all of them, so you can prescale by e.g. a factor of 100

• Enough events for the analysis

Low E_T^{miss}	A (bkg enriched)	B (mainly bkg)
High E_T^{miss}	C (Signal + bkg)	D (bkg enriched)
	Pass e^\pm identif.	Fail e^\pm identif.

What other triggers do I need: efficiency extraction

- Trigger efficiency needs to be precisely measured since it enters in the calculation of the cross-sections

$$\epsilon_{\text{trig}} = \frac{\text{Number of events passing trigger selection}}{\text{Number of events without trigger selection}}$$

- Trigger efficiency is usually measured w.r.t. offline, such that

$$\sigma(\text{signal}) = \frac{(N_{\text{cand}} - N_{\text{bkg}})}{\alpha \cdot \epsilon_{\text{trig}} \cdot \epsilon_{\text{offline}} \cdot \int L dt} \text{ with } \epsilon_{\text{trig}} = \epsilon(L1) \cdot \epsilon(L2) \cdot \epsilon(L3)$$

- Your trigger is used to collect your data

 You cannot blindly use your data to study efficiency as your trigger might have introduced a bias

- Need an unbiased measurement of trigger and offline efficiency

Methods for trigger efficiency measurements

- Random sample of collisions
 - Bootstrapping via pass-through triggers
 - Use looser trigger, e.g. apply only L1 selection, but nothing at L2, L3
- $$\varepsilon(\text{L2 mu20}) = \frac{\text{events passing L2 mu20}}{\text{events passing L2 mu20 in pass-through}}$$
- Drawback: you might measure the efficiency of your signal plus some background
 - Use “orthogonal” trigger
 - Trigger on certain particle type in the event, measure another one
 - For example use muon triggered events to measure electron trigger efficiency
 - Method might suffer from your topology (you might select more (less) crowded events), you measure signal + background
 - Use simulations
 - Monte-Carlo must very well describe the data

Efficiency Measurement

- Use well-known physics processes and do “tag & probe”
 - $Z \rightarrow ll, J/\Psi \rightarrow ll$: trigger only on one leptons
 - Most precise way to calculate efficiencies
 - $W \rightarrow lv$: trigger on missing E_T
- Example: $Z \rightarrow ee$ tag and probe
 - Trigger on one of the electrons
 - Select offline events with 2 good electrons which have an invariant mass around the Z mass
 - “tag” electron: well identified, coincides with electron which triggered event
 - “probe” electron: check if this one passed or failed the trigger selection

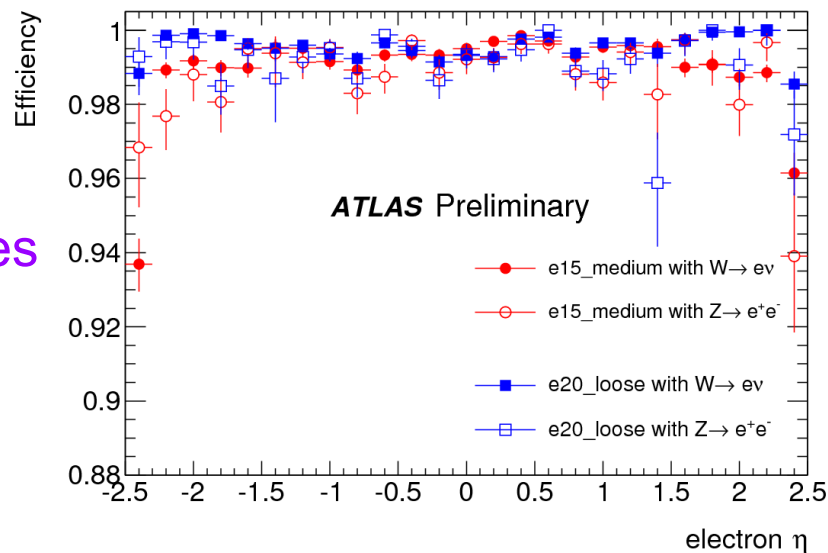
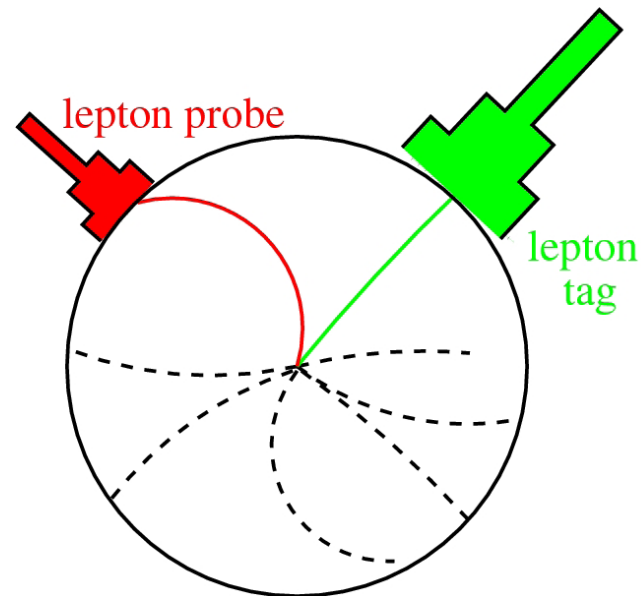

Summary: triggers for W cross section measurement

• Trigger to select signals

- Well identified electrons/muons with $E_T > 25$ GeV and certain identification criteria

 - Might even consider prescaling

- electron/muon with $E_T > 25$ GeV and $E_T^{\text{miss}} > 30$ GeV

• Trigger needed for background subtractions

- Prescaled trigger with loosely identified electron/muon candidates with $E_T > 25$ GeV

• Triggers for efficiency extraction

- Well identified electrons/muons with $E_T > 25$ GeV (use the electrons from Z decays)

- E_t^{miss} trigger to measure offline efficiency from W decays

Example 2: Measurement of direct photon production

- Measure spectrum starting with $E_T > 15$ GeV
- Can't keep all the collisions with photons at low E_T
 - Use prescaled triggers
 - g10, g20, g40, g60, etc until rate low enough
 - Prescale each trigger to give ~ 1 Hz rate
 - Trigger for background extraction
 - If photons loosely selected, can use same sample to extract the background from jets faking γ 's
 - Identification criteria vs isolation

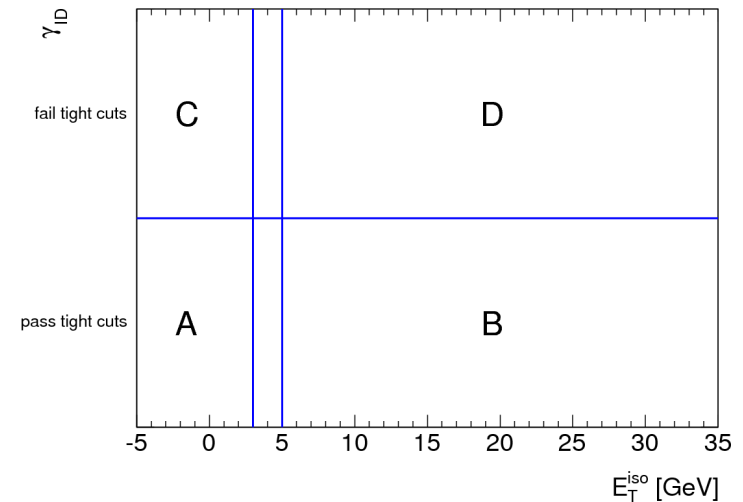
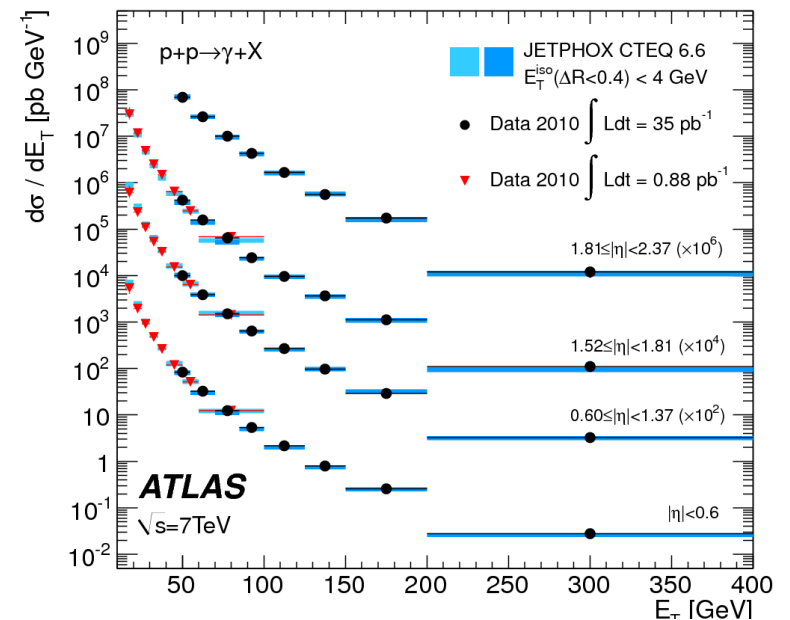

Example 2: Measurement of direct photon production

Efficiency

Use bootstrapping

- use photon candidates selected by L1 only, measure photon efficiency w.r.t. L1

- Use unbiased sample e.g. minimum bias to measure L1 efficiency

- $\epsilon_{\text{Trigger}} = \epsilon_{\text{L1}} \cdot \epsilon_{\text{L2, L3}}$

- Advantage: 2-step approach results in less overall statistics needed due to high rejection at each trigger level

Use Z→eey events (tag & probe)

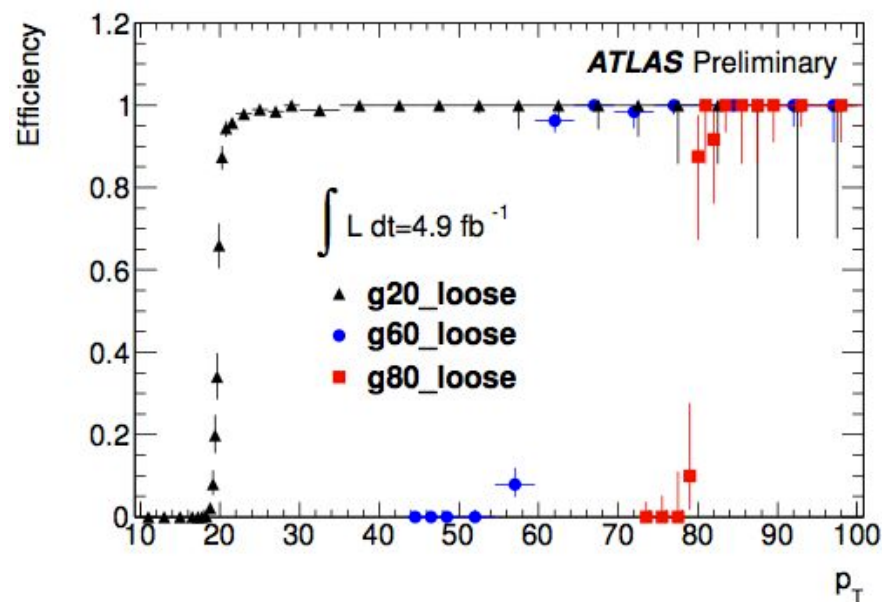

Example 3: $B \rightarrow J/\psi K$ (LHCb)

- Select events with
 - Displaced vertex
 - 2 muons from J/ψ decay
 - Muons come from displaced vertex
- Such a trigger is also useful for other analyses
 - $B \rightarrow \mu\mu$, $B_s^0 \rightarrow J/\psi \phi$, $B^0 \rightarrow K^{*0} \mu\mu$
- If you can't afford the rate
 - Muons need to fall in inv. mass window around J/ψ mass
 - Combine with loosely identified K

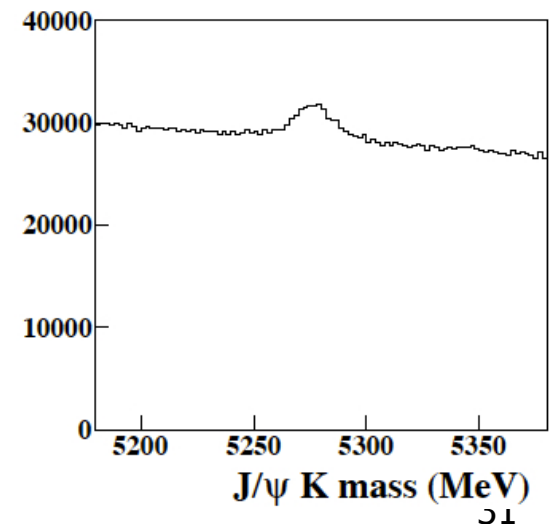
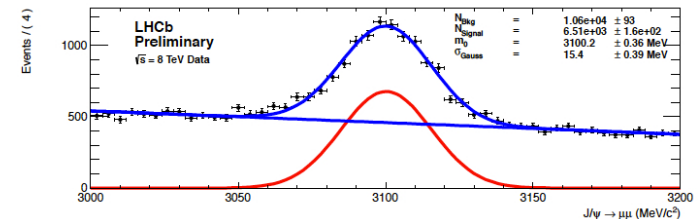
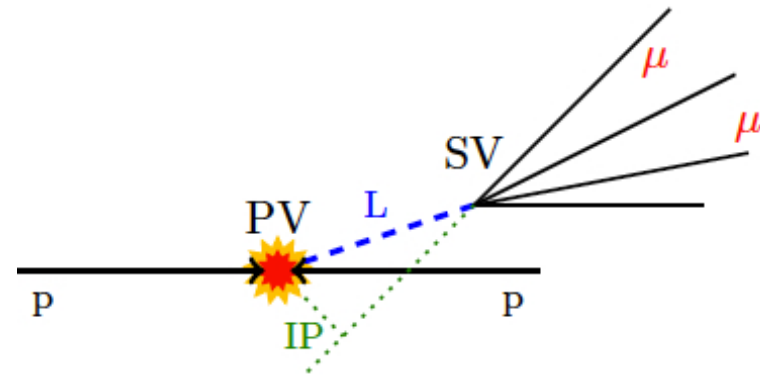

Preparing for LHC run 2

- Have to become even more selective due to pileup, increasing beam energy
 - Forced to throw away more of potentially interesting candidates or increase rate of events writing to mass storage
 - Cannot rely so much any more on single particle triggers
 - Rate of $W \rightarrow l\nu$ at $\sqrt{s} = 14 \text{ TeV}$ $L = 10^{34} \text{ cm}^{-2}\text{s}^{-1}$ is $\sim 100\text{-}150 \text{ Hz}$
 - Single object triggers might need to increase threshold above W-peak
 - Need to have more combined triggers using identified particles
 - Need to have more topological trigger, select events with W/Z candidates, back-to-back signatures, etc.
- We decided to write out 1 kHz instead of $\sim 300\text{-}400\text{ Hz}$ in order not to throw away too much good physics...

Summary

• Introduction to trigger selection

- Introduction to some slang: trigger path, trigger menu...
- Trigger strategy is trade-off between physics requirements and affordability
- How to devise a trigger for a physics analysis
 - Will be (hopefully) useful for your physics analysis