

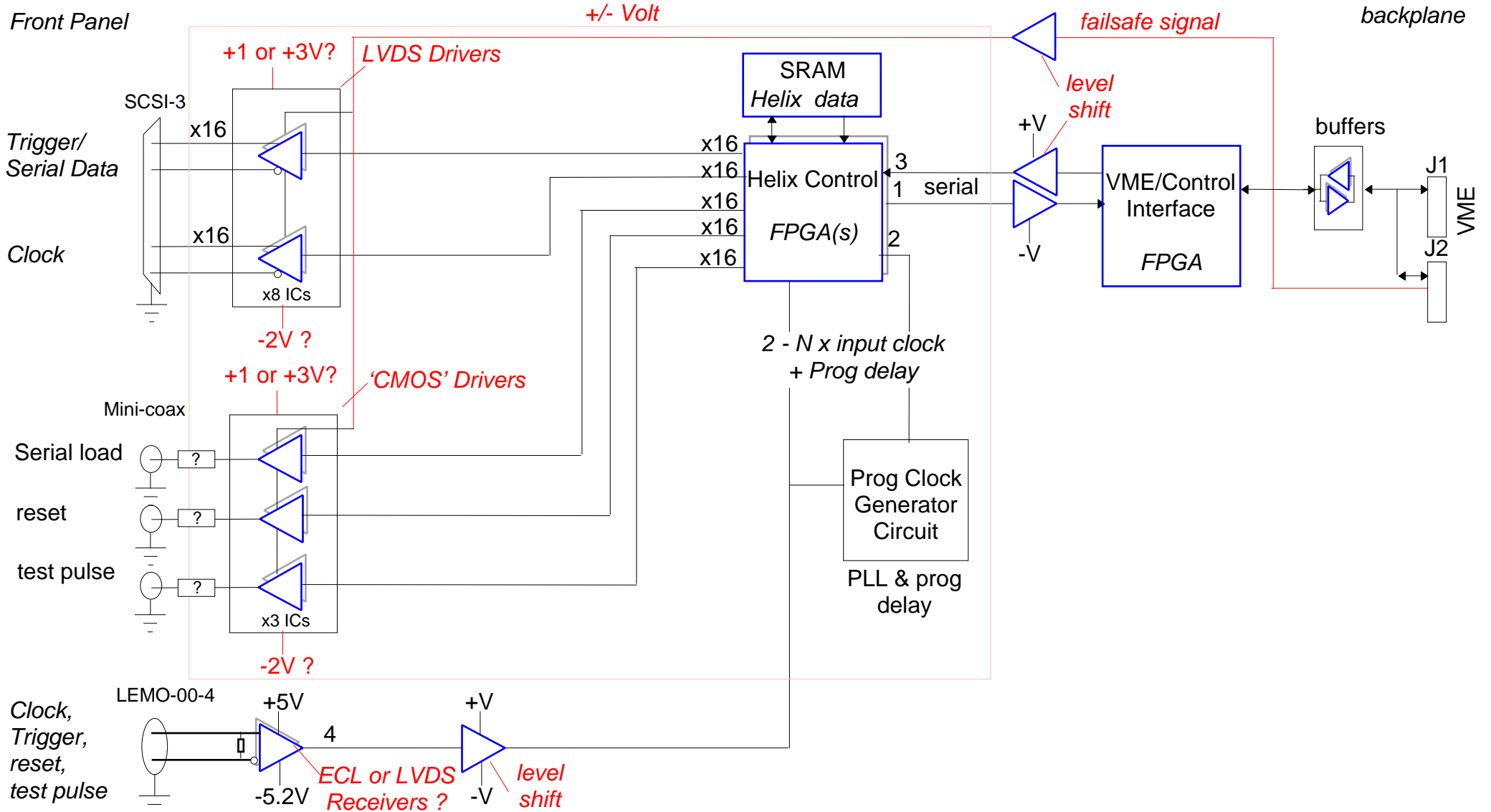

ZEUS Micro Vertex Detector

Helix Interface - Driver Proposal

6Ux160mm - VME Module





ZEUS Micro Vertex Detector Helix Interface

6U - 223mm x 160mm - VME Module

Helix Driver/x16 Fanout/Connectors/Proposal

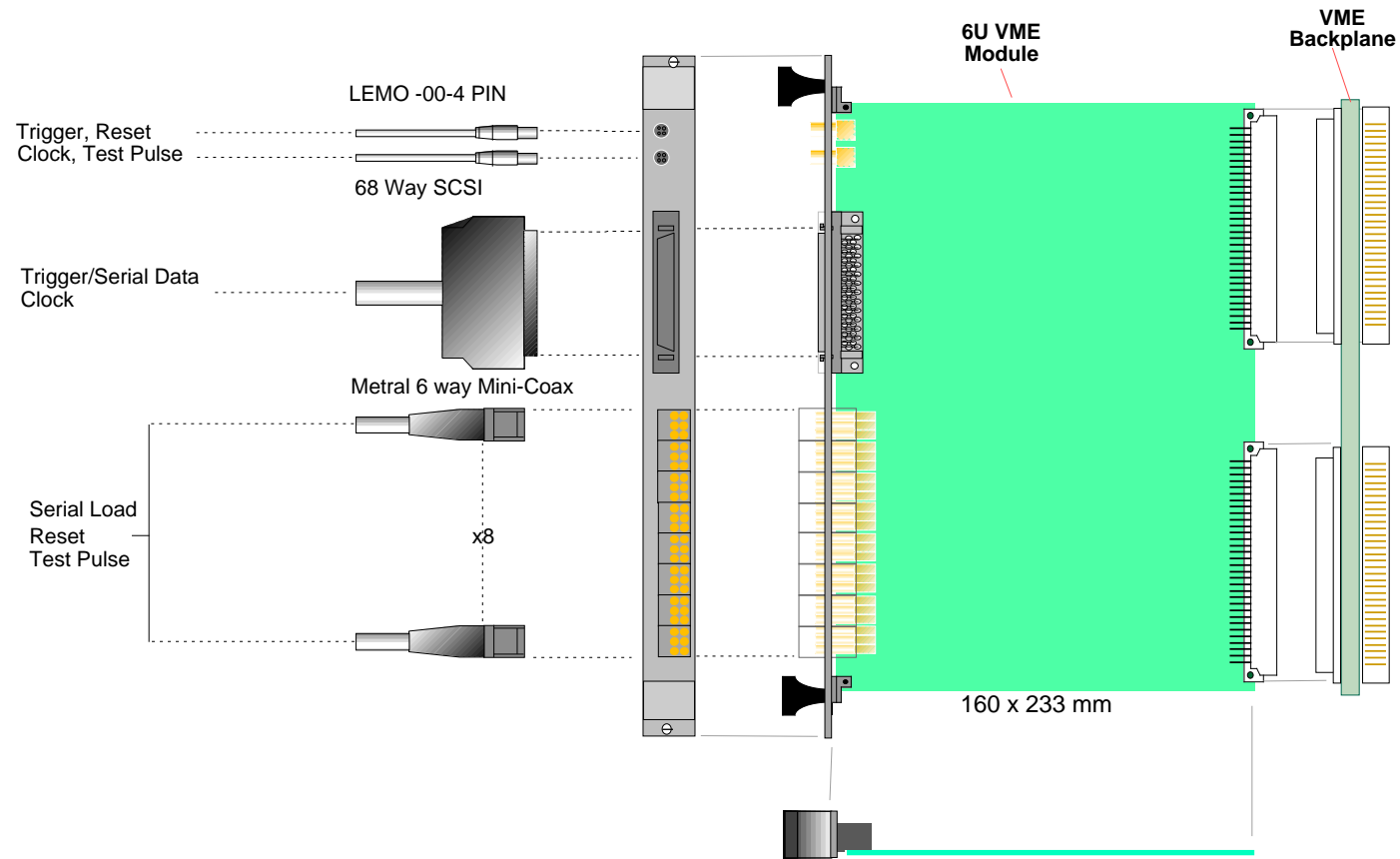



ZEUS Micro Vertex Detector

Helix Driver - FPGA Fanout

FPGA Trig/serial Data Circuit

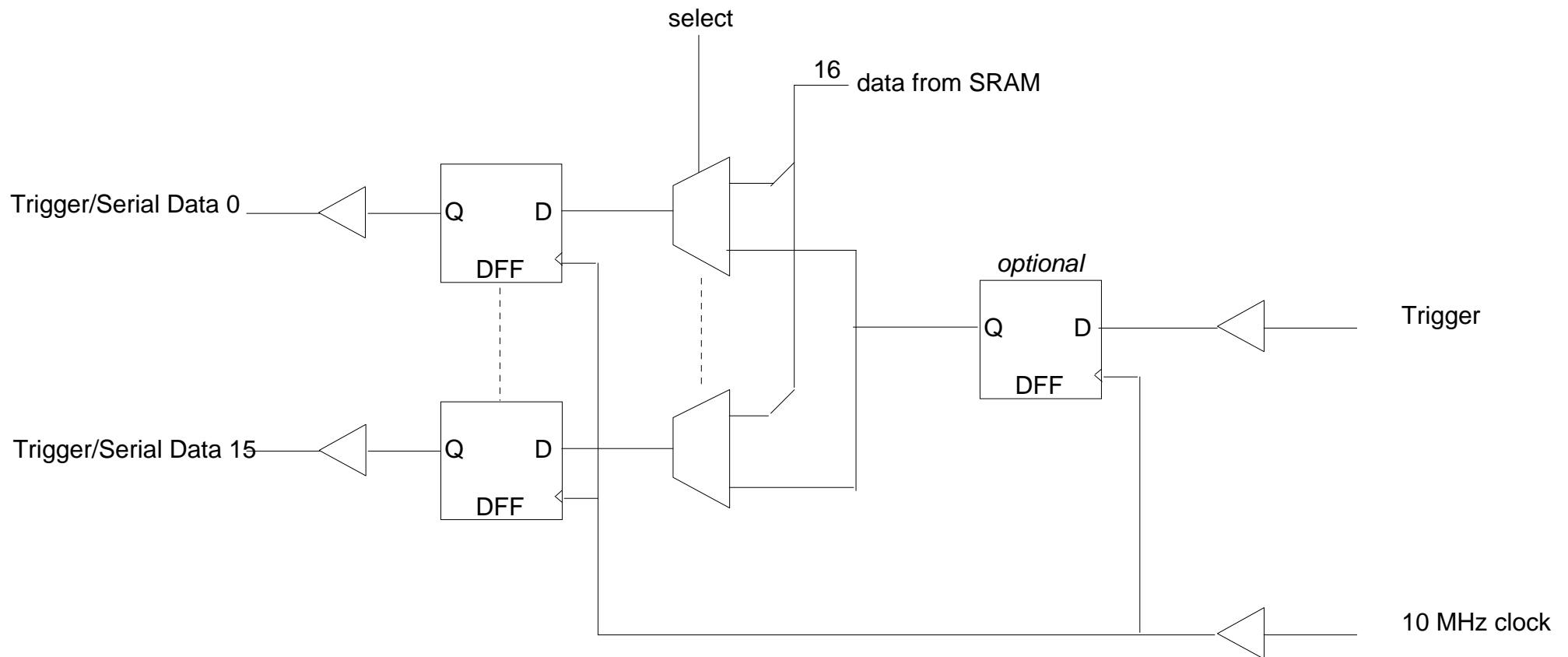

Trigger Pipelined



ZEUS Micro Vertex Detector

Helix Driver - FPGA Fanout

FPGA Reset Circuit

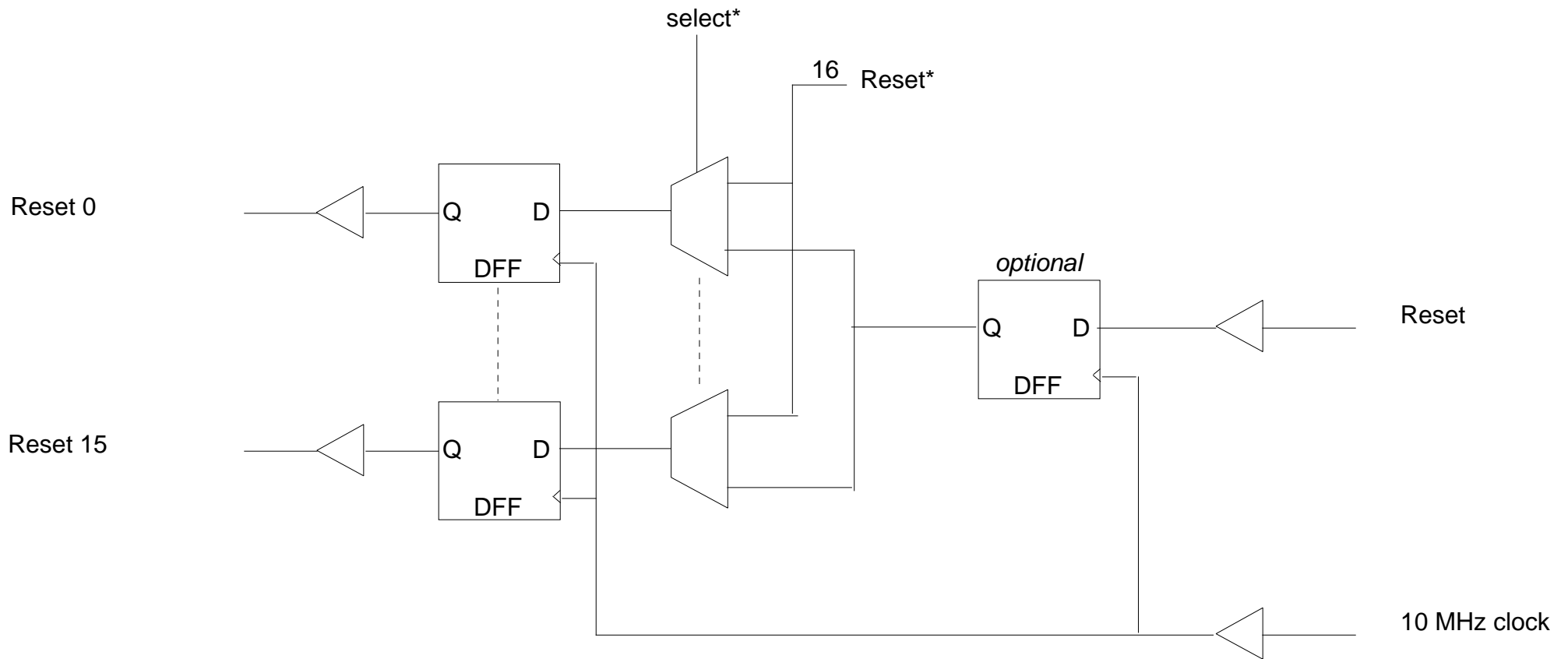

Reset Pipelined

signals marked * from internal state machine



ZEUS Micro Vertex Detector

Helix Driver - FPGA Fanout

FPGA Load Circuit

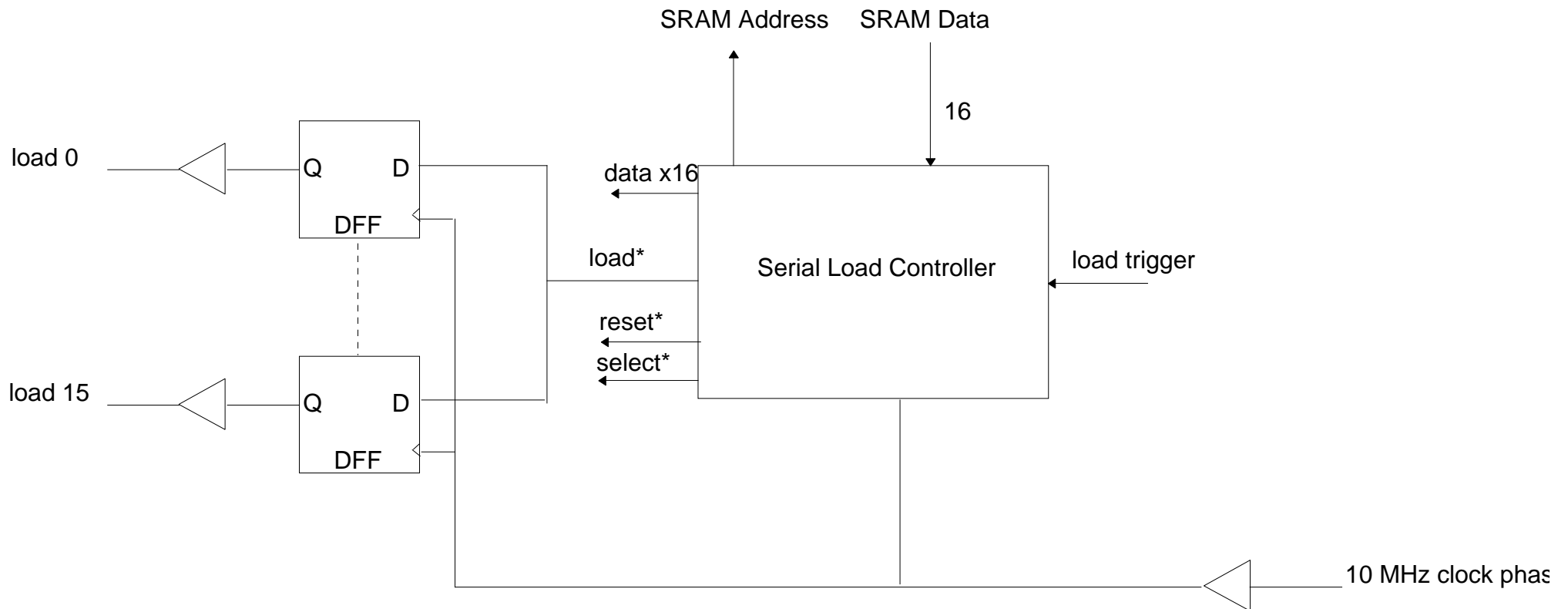

signals marked * from internal state machine
signals marked # from internal registers



ZEUS Micro Vertex Detector

Helix Driver - FPGA Fanout

FPGA Test Pulse Circuit

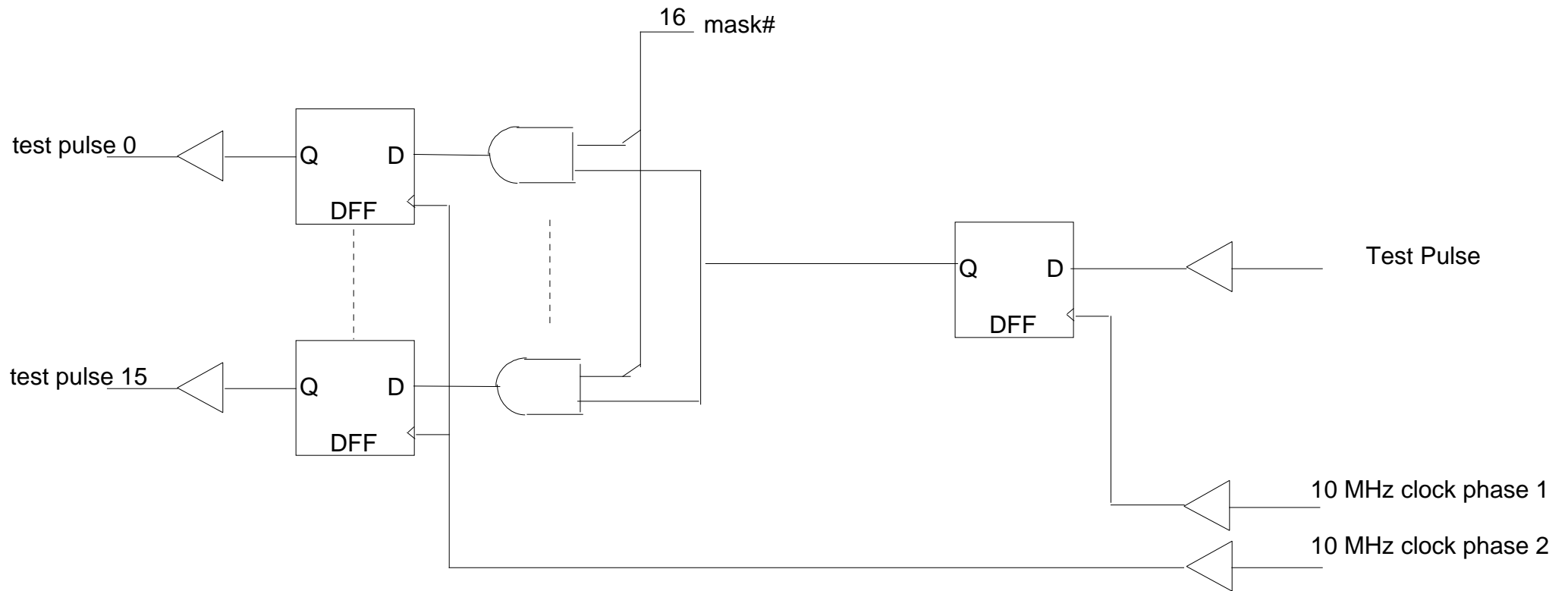

signals marked * from internal state machine

signals marked # from internal registers



ZEUS Micro Vertex Detector

Helix Interface - Driver Module

CMOS Driver transmission & termination

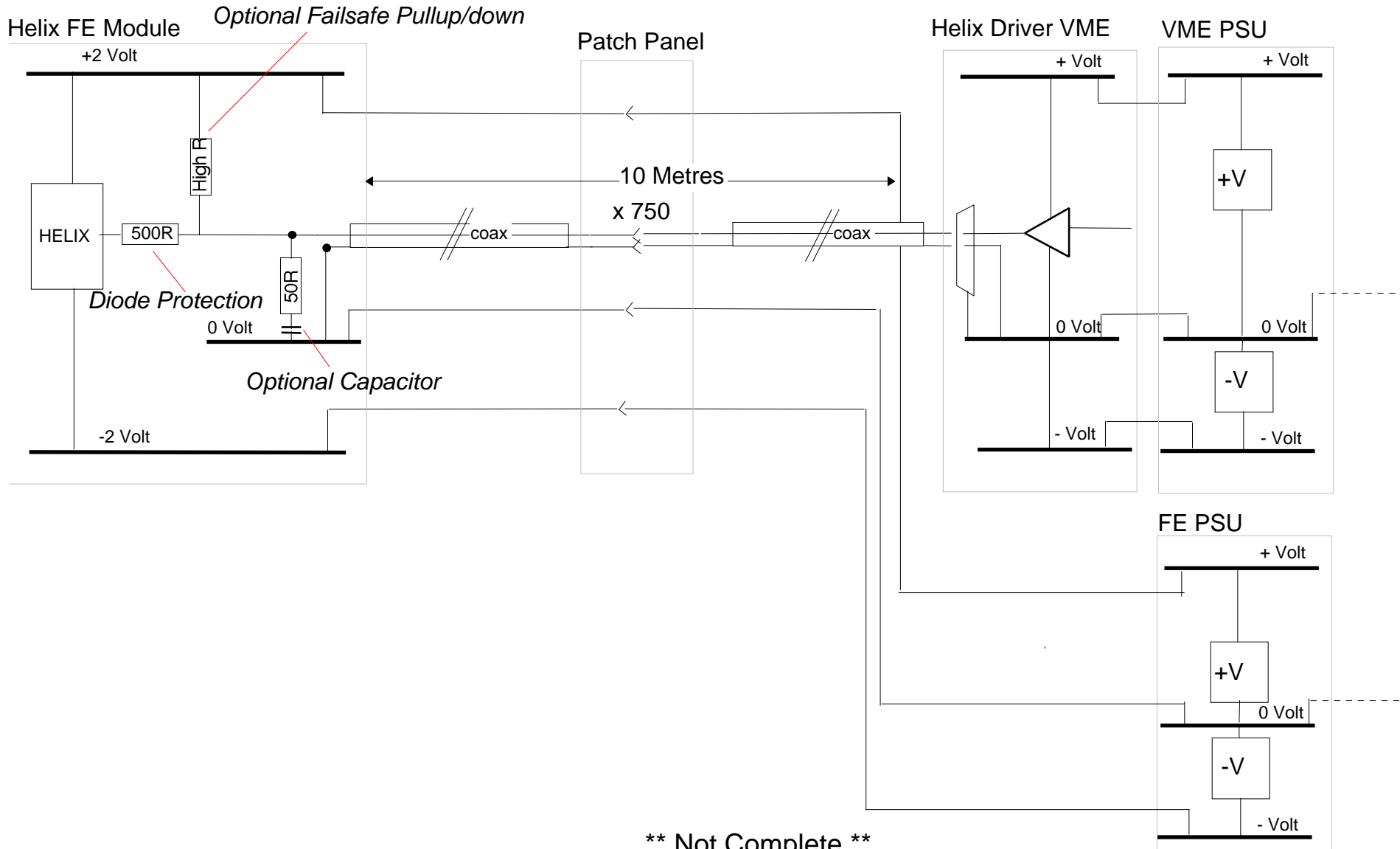

** Not Complete **



ZEUS Micro Vertex Detector

Helix Interface - Driver Module

CMOS Driver transmission & termination

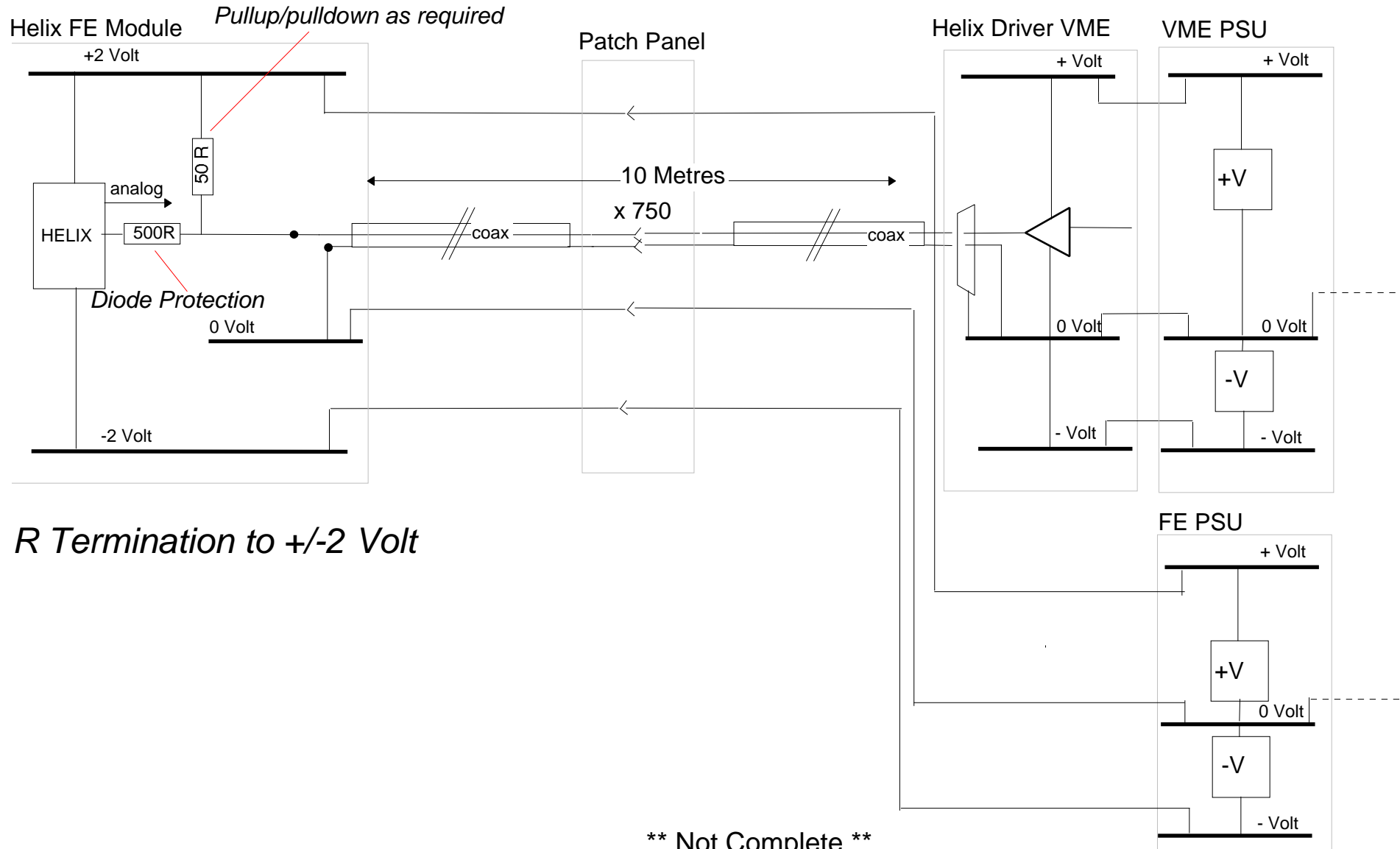

** Not Complete **



ZEUS Micro Vertex Detector

Helix Interface - Driver Module

LVDS Driver transmission & termination

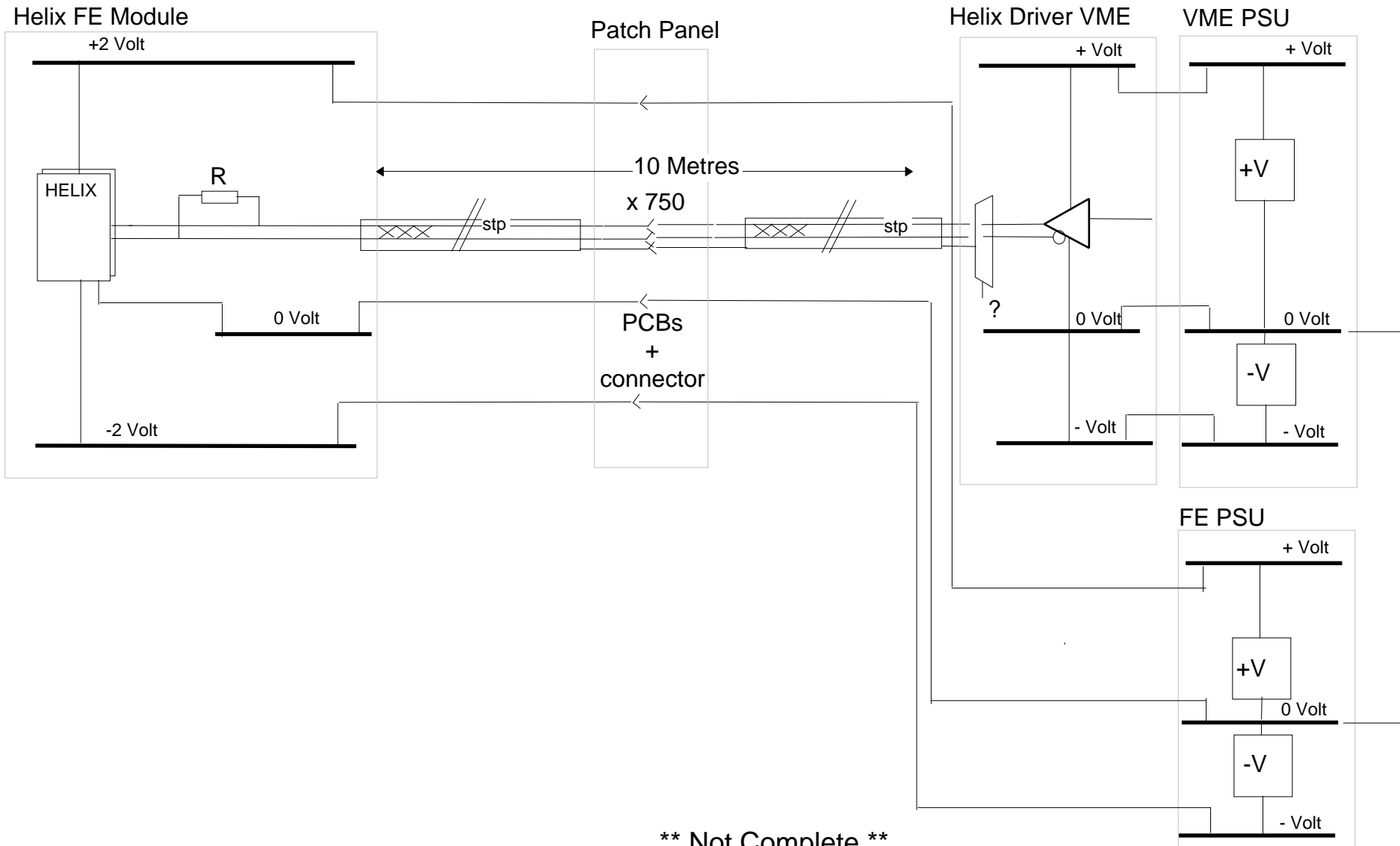

** Not Complete **